

# CLEAN-CEIL

## Economy Work Stations

A cost-effective, energy efficient, light weight alternative to traditional Horizontal and Vertical Laminar Flow Work Stations



The CLEAN-CEIL family of Vertical and Horizontal Laminar Flow Clean Air Work Stations, and Reverse Flow Work Stations may be used as either Bench Top or Console Units. Our unique modular design allows you to choose the optional accessories necessary to meet your requirements and to assemble the stations on-site within minutes.

CLEAN-CEIL provides you with a localized particulate-free environment... exactly where you need it!

# CLEAN-CEIL

## Vertical Laminar Flow

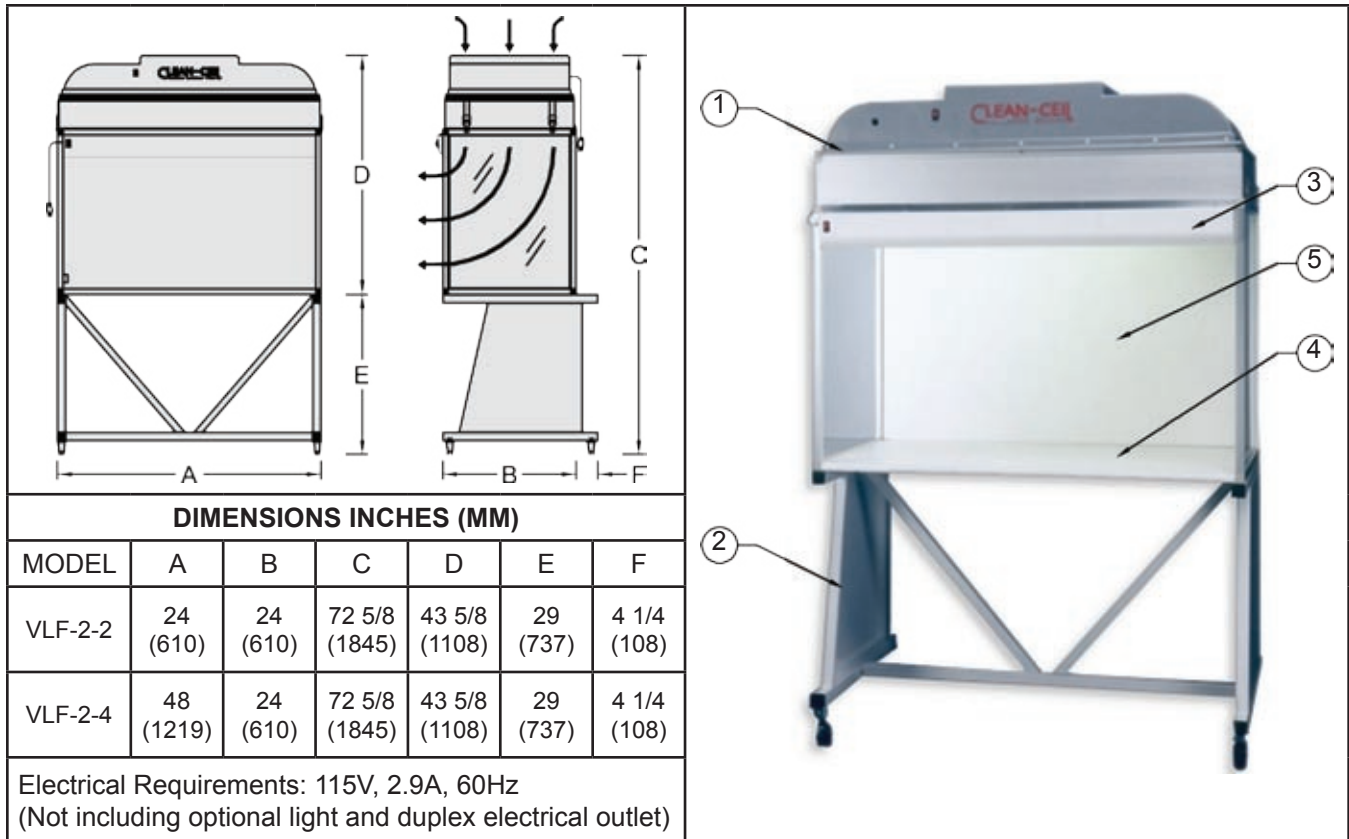

### Ordering Information

ITEM	DESCRIPTION	PART #
1	Nominal width Vertical Laminar Flow Work Station - includes CLEAN-CEIL fan/filter module, aluminum support frame and clear acrylic top and side panels. Model VLF-2-2 nominal 2ft. wide, model VLF-2-4 nominal 4ft. wide.	VLF-2-2 VLF-2-4
2	Optional painted steel base frame to form console unit	FFM-132
3	Optional fluorescent light fixture	FFM-130
4	Optional countertops: Stainless steel Plastic laminate Antistatic plastic laminate Polypropylene	SSCT PLCT APLCT PPCT
5	Optional back panels: Stainless steel Polypropylene	SSBP PPBP
6	Optional Minihelic gauge to monitor loading on HEPA/ULPA filter	ECL0101
7	Optional I.V. bar	IV-4
8	Optional gas, air or vacuum turrets	T00106
9	Optional duplex electrical outlet	UA-116
10	Replacement washable pre-filter	UA-043
11	Replacement HEPA filter rated 99.99% efficient at 0.3 microns	GA-049
12	Optional ULPA filter rated 99.9995% efficient at 0.12 microns	ULPA-2-4

# CLEAN-CEIL

## Horizontal Laminar Flow

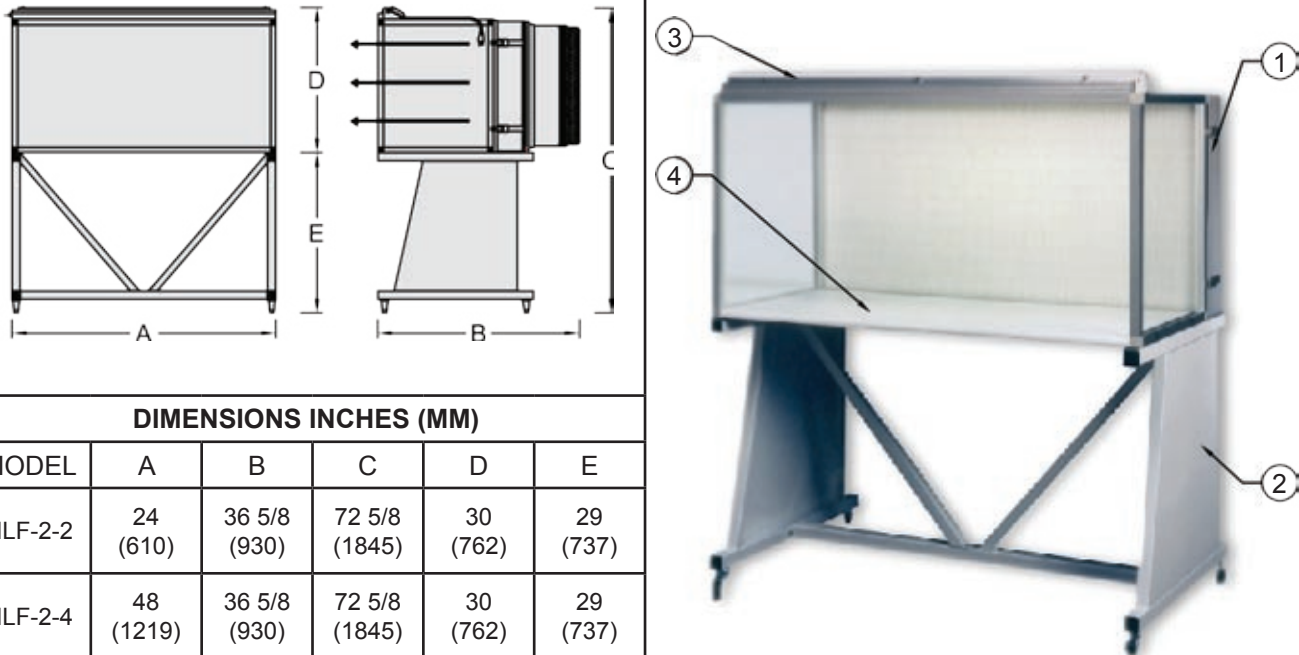

DIMENSIONS INCHES (MM)					
MODEL	A	B	C	D	E
HLF-2-2	24 (610)	36 5/8 (930)	72 5/8 (1845)	30 (762)	29 (737)
HLF-2-4	48 (1219)	36 5/8 (930)	72 5/8 (1845)	30 (762)	29 (737)

Electrical Requirements: 115V, 2.9A, 60Hz  
(Not including optional light and duplex electrical outlet)

## Ordering Information

ITEM	DESCRIPTION	PART #
1	Nominal width Horizontal Laminar Flow Work Station - includes CLEAN-CEIL fan/filter module, aluminum support frame and clear acrylic top and side panels. Model HLF-2-2 nominal 2ft. wide, model HLF-2-4 nominal 4ft. wide.	HLF-2-2 HLF-2-4
2	Optional painted steel base frame to form console unit	FFM-132
3	Optional fluorescent light fixture	FFM-130
4	Optional countertops: Stainless steel Plastic laminate Antistatic plastic laminate Polypropylene	SSCT PLCT APLCT PPCT
5	Optional Minihelic gauge to monitor loading on HEPA/ULPA filter	ECL0101
6	Optional I.V. bar	IV-4
7	Optional gas, air or vacuum turrets	T00106
8	Optional duplex electrical outlet	UA-116
9	Replacement washable pre-filter	UA-043
10	Replacement HEPA filter rated 99.99% efficient at 0.3 microns	GA-049
11	Optional ULPA filter rated 99.9995% efficient at 0.12 microns in lieu of HEPA filter	ULPA-2-4

# CLEAN-CEIL

## Class 1 Biological Safety Cabinet

DIMENSIONS INCHES (MM)						
MODEL	A	B	C	D	E	F
VRF-2-2	24 (610)	24 (610)	72 5/8 (1845)	43 5/8 (1108)	29 (737)	4 1/4 (108)
VRF-2-4	48 (1219)	24 (610)	72 5/8 (1845)	43 5/8 (1108)	29 (737)	4 1/4 (108)

Electrical Requirements: 115V, 2.9A, 60Hz  
(Not including optional light and duplex electrical outlet)

### Ordering Information

ITEM	DESCRIPTION	PART #
1	Reverse Flow Work Station - includes CLEAN-CEIL reverse flow fan/filter module, aluminum support frame and clear acrylic side panels, stainless steel back panel, rear baffle, hinged acrylic face shield and a granular activated carbon filter on the exhaust.* Model VRF-2-2 nominal 2ft. wide, model VRF-2-4 nominal 4ft. wide.	VRF-2-2 VRF-2-4
2	Optional painted steel base frame to form console unit	FFM-132
3	Optional fluorescent light fixture	FFM-130
4	Optional countertops: Stainless steel Plastic laminate	SSCT PLCT
5	Optional Minihelic gauge to monitor loading on HEPA/ULPA filter	ECL0101
6	Optional gas, air or vacuum turrets	T00106
7	Optional duplex electrical outlet	UA-116
8	Replacement washable pre-filter	UA-043
9	Replacement HEPA filter rated 99.99% efficient at 0.3 microns	GA-049
10	Replacement carbon filter	UA-650

# Specifications

<b>Air System</b>	All units utilize the CLEAN-CEIL fan/filter module.	<b>Speed Control</b>	Standard SCR speed controller
<b>Cleanliness Level</b>	Provides better than ISO CLASS 5, (CLASS 100 conditions as per U.S. Federal Standard 209E).	<b>Wiring</b>	The electrical termination is a 7ft. cord with grounded plug.
<b>Air Velocity</b>	90 ± 20 ft/min. (27.5 ± 6 m/min) average when measured six inches from filter face without the use of a speed control. *	<b>Voltage</b>	Standard voltage: 115V, 60Hz Optional voltage: 220V, 50Hz
<b>HEPA Filter</b>	Standard filter is 99.99% minimum efficiency rated for all particulates 0.3 microns and larger.	<b>Lighting</b>	Provides approximately 75 foot candles at the work surface.
<b>ULPA Filter</b>	Optional filter is 99.9995% minimum efficiency as measured using a laser scan method at 0.12 microns. +	<b>Noise Level</b>	Vertical Work Stations: Less than 62.5 db on the "A" scale. Horizontal Work Stations: Less than 64.5 db on the "A" scale. As per IES-RP-CC-002-86.
<b>Pre-filter</b>	Washable type 40% efficiency as per ASHRAE 52.1  + ULPA filters are recommended for ISO CLASS 4 (CLASS 10) conditions.  * For applications requiring specific air-flows the motorized impeller may be controlled by the SCR speed control	<b>Vibration Level</b>	Less than 100 microinches rms. As per IES-RP-CC-002-86.
		<b>Certification</b>	All units factory leak checked and certified prior to shipment.
		<b>Electrical</b>	Certified to CSA and OSHA.

**Note:** Specifications subject to change

# Shipping Information

The work stations are shipped in cartons as follows:

- 1. Clean-Ceil Module.....60 lbs (27 kilos)
- 2. Aluminum tube support frame, side.....75 lbs (34 kilos)  
shields and accessories
- 3. Painted steel console base.....50 lbs (23 kilos)



86 Harry Douglas Drive  
Ottawa, Ontario, Canada K2S 2C7  
Tel: (613) 831-8318  
Toll Free: (877) 252-7710  
Fax: (613) 831-8321  
E-Mail: sales@microzone.com  
www.microzone.com

**Local Representative:**